

Potain Igo 26

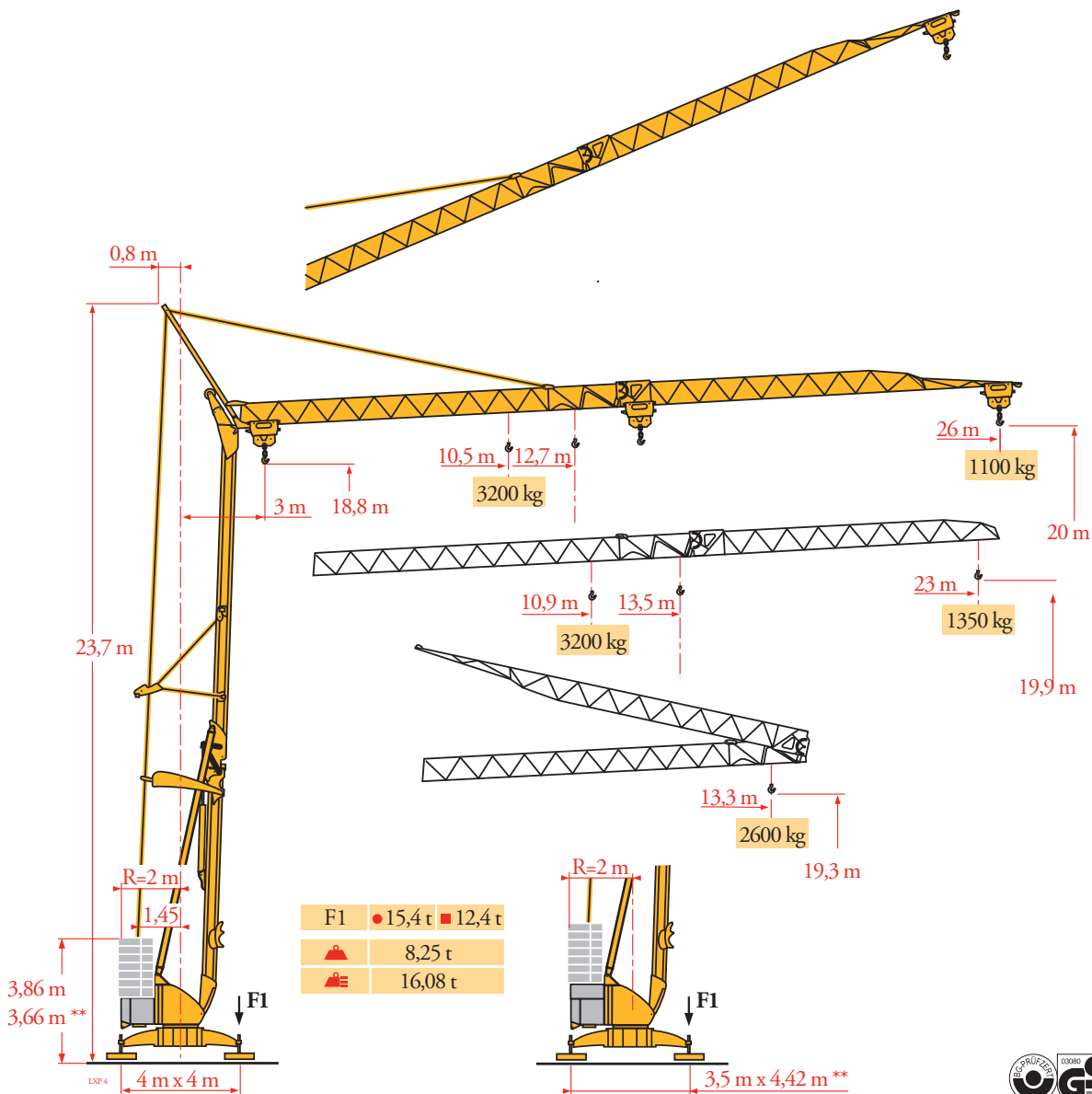

Courbes de charges
Lastkurven
Load diagrams
Curvas de cargas
Curve di carico
Curva de cargas
Диаграммы
грузоподъемностей

LXP₄

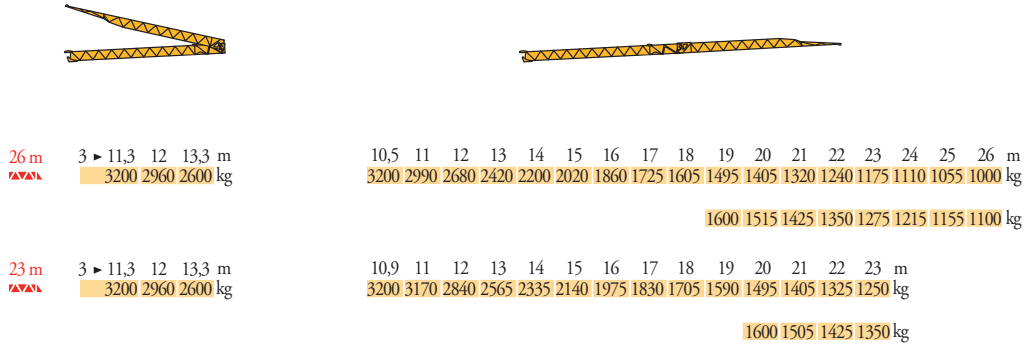

Flèche relevée
Ausleger in
Steilstellung
Luffing jib
Flecha izada
Braccio impennato
Lança inclinada
Маховая стрела

LXP₅

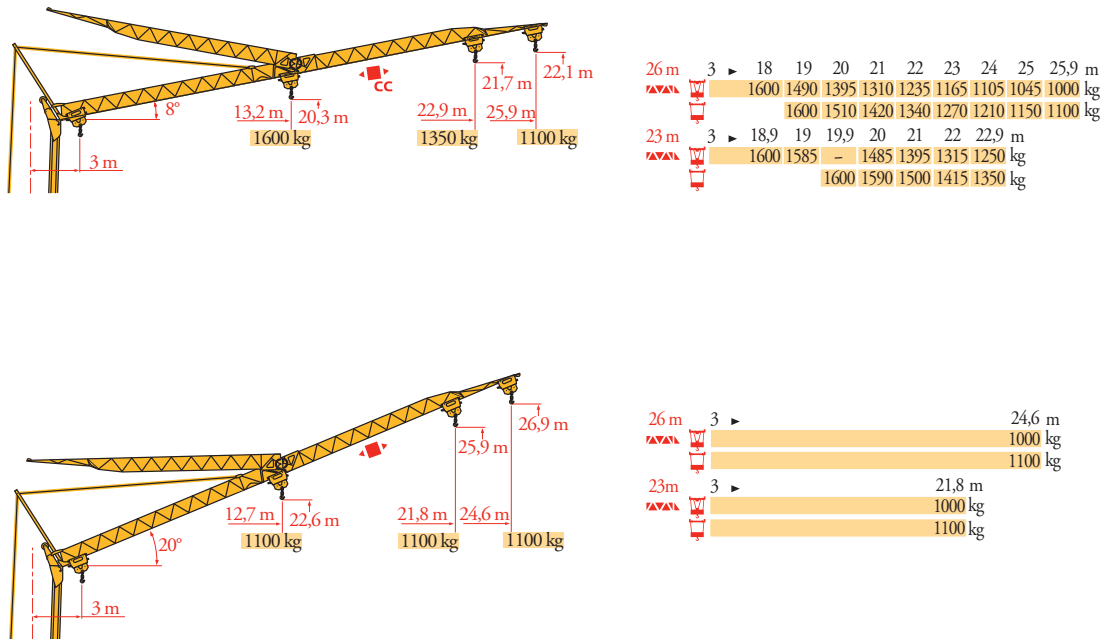

FR



Chariot distributeur
Chariot distributeur et
courbes de charges
Réactions en service
Réactions hors service



A vide sans lest (ni train de
transport) avec flèche et
hauteur maximum



Poids total du lest

DE

Verfahrbare Laufkatze
Verfahrbare Laufkatze und
Lastkurven
Reaktionskräfte in Betrieb
Reaktionskräfte außer
Betrieb

Ohne Last, Ballast (und
Transportachse), mit
Maximalausleger und
Maximalhöhe

Ballast-Gesamtgewicht.

EN

Traversing trolley
Traversing trolley and load
diagrams
Reactions in service
Reactions out of service

Without load, ballast (or
transport axles), with
maximum jib and
maximum height

Gross ballast weight.

ES

Carro distribuidor
Carro distribuidor y curvas
de cargas
Reacciones en servicio
Reacciones fuera de servicio

Sin carga, sin lastre, (ni tren
de transporte), flecha y
altura máxima

Peso total del lastre.

IT

Carrellino distributore
Carrellino distributore e
curve di carico
Reazioni in servizio
Reazioni fuori servizio

A vuoto, senza zavorra (ne
assali di trasporto) con
braccio massimo e altezza
massima

Peso totale della zavorra.

PT

Carro distribuidor
Carro distribuidor e curva de
cargas
Reacções em serviço
Reacções fora de serviço

Sem carga (nem trem de
transporte)- sem lastro com
lança e altura máximas

Peso total do lastro.

RU

Грузовая тележка
Грузовая тележка и диаграммы
грузоподъемностей
Реакции при работе
Реакции в покое

Вес без груза, балласта (или
транспортных осей), с
максимальной длиной стрелы и
максимальной высотой

общий вес груза

Mécanismes
Antriebe
Mechanisms
Mecanismos
Meccanismi
Mecanismos
Механизмы

LXP5

			⚙️					⚙️					ch - PS hp	kW	
⬆️	15 LVF 10 Optima	m/min	3,6	18	37	49	66						15	11	
		kg	1600	1600	1600	1100	500								
		m/min	3,6	18	37	54	66	1,8	9	19	27	33			
		kg	1600	1600	1600	1000	500	3200	3200	3200	2000	1000			
⬆️	3 DVF5	m/min	19 - 41										3	2,2	
⚙️	RVF2	tr/min U/min rpm	0 → 0,8										2	1,5	
⚡ IEC 60204-32							⚡ kVA								
400 V(+10% -10%) 50 Hz 480 V(+ 6% -10%) 60 Hz							15 LVF 10 : 20 kVA								

15 LVF 10
Optima

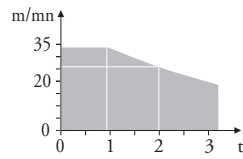

Montage
Montage
Erection
Montaje
Montaggio
Montagem
Монтаж

LXP3

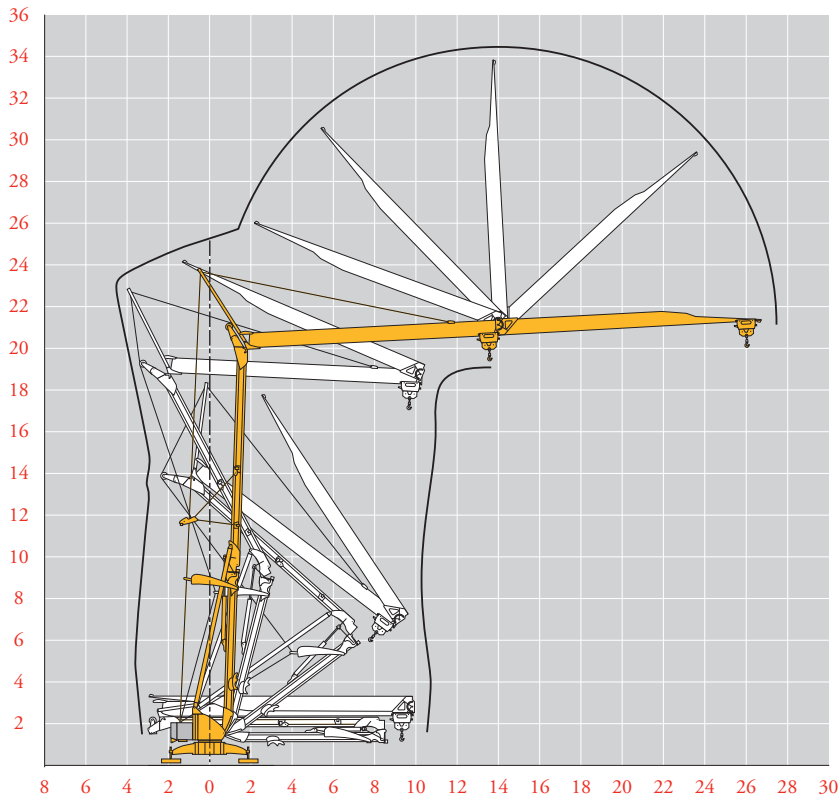

FR

Levage
Distribution
Orientation

DE

Heben
Katzfahren
Schwenken

EN

Hoisting
Trolleying
Slewing

ES

Elevación
Distribución
Orientación

IT

Sollevamento
Distribuzione
Rotazione

PT

Elevação
Distribuição
Rotação

RU

Подъем
Перемещение каретки
Поворот

Transport
 Transport
 Transport
 Transporte
 Trasporto
 Transporte
 Транспортировка

LXP5

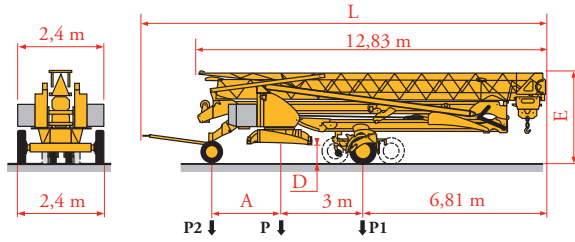

	Km/h	A (m)	D (m)	E (m)	L (m)	P (kg)	P1 (kg)	P2 (kg)
DS62/S120	10	2,35	0,36/0,21	3,2/3,05	14,48	13860	9000	4860
DS61/S125	25	2,45	0,36/0,21	3,2/3,05	14,77	14205	9290	4915

... **

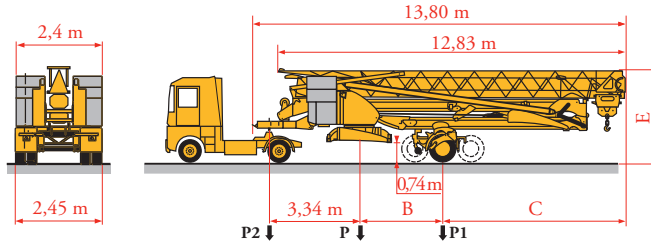

	Km/h	B (m)	C (m)	E (m)	P (kg)	P1 (kg)	P2 (kg)
SL121/J135	25	3,00	6,81	3,85	21520/15120	12920/10920	8600/4200
SL122/J215M	80	5,37	4,44	3,58	22590/16190	10910/ 9510	11620/6670

... **



**

FR

Transport grue toute lestée.

Voir documentations techniques.

DE

Krantransport mit voller Ballastierung.

Siehe technische Dokumentation.

EN

Transport of crane with full ballast.

See technical documentations.

ES

Transporte grúa completamente lastrada.

Consulte la documentación técnica.

IT

Trasporto con gru completamente zavorrata.

Vedere la documentazione tecnica.

PT

Transporte de grua totalmente balastrada.

Consultar documentações técnicas.

RU

Перевозка крана с полным балластом

см. техническую документацию



Document commercial non contractuel. Pour toute information technique se référer à la notice correspondante.

Unverbindliches Vertriebsdokument. Für technische Informationen, siehe die entsprechenden Anweisungen.

This commercial document is not legally binding. For any technical information, please refer to the corresponding instructions.

Documento comercial no contractual. Para cualquier información técnica, ver la noticia correspondiente.

Documento commerciale non vincolante. Per tutte le informazioni tecniche fare riferimento al catalogo istruzioni.

Documento comercial não contratual. Para qualquer informação técnica complementar consultar as respectivas instruções.

Этот коммерческий документ не является юридически обязательным. Для получения технической информации, см. соответствующие инструкции.



Manitowoc - Americas - World Headquarters
 2400 S. 44th Street • Manitowoc • WI 54220 USA
 Tel: +1 920 684 4410 • Fax: +1 920 652 9778

Manitowoc - Europe, Middle East & Africa
 Ecully, France
 18, rue de Charbonnières B.P. 173 • 69132 ECULLY Cedex • FRANCE
 Tel: +33 (0)4 72 18 20 20 • Fax: +33 (0)4 72 18 20 00

Manitowoc - Asia Pacific
 16F Xu Hui Yuan Building,
 1089 Zhongshan No.2 Road (S) • Shanghai 200030 China
 Tel: +86 21 6457 0066 • Fax: +86 21 6457 4955

REF: 200648 LXP7